

## MPT800 Series

### Miniature Pressure Sensor

#### Applications

Aerospace  
Automobile Manufacturing  
Petroleum and Petrochemical  
Industrial Automation  
Shipbuilding  
Construction Machinery

#### Features

High Precision and Stability  
Superior Environmental Adaptability  
Flexible Customization  
Fast Response and Low Power Consumption  
Comprehensive Safety Certification  
High Frequency

#### Profiles

The MPT800 series pressure sensor is a miniature, multi-functional, high-precision pressure sensor.

Advanced micromachined silicon technology MEMS chip, special oil-filled media isolation, solid anti-interference circuit design and stainless steel internal and external structural interfaces make the MPT800 series a high-precision, reliable pressure sensor suitable for a wide range of measurement media.

Through the front design of the pressure core, the series has a small size, wide range, and high pressure resistance. The sensor can provide a variety of different electrical output signals and output methods, and can measure two types of pressure: adiabatic pressure and sealed gauge pressure.





# DATASHEET

## PRESSURE MEASUREMENT

Dabey Technology Co., LTD  
 Sales@dabeysensor.com  
 86-18890003683  
 www.dabeysensor.com

Power-up Time	A、 B <1ms D <200ms
Zero and Full-Scale Output Range	Rating within $\pm 5\%FS$ Other requirements can be customized
Insulation Resistance	$\geq 100M\Omega@50VDC$
Electrical strength	leakage current $\leq 5mA@50VAC$ RMS
Maximum Operating Current	D<25mA
Input Impedance	A、 B >5000 $\Omega$
Output impedance	A、 B 5000 $\Omega$ D <150 $\Omega$
Long-term stability	Typical values $\pm 0.1\%FS^5$
Electrical connection	See selection table, can be customized

### Temperature Performance

Specifications	Description
Temperature Compensation Range	Selectable within the range of -40°C to 125°C
Operating and storage temperature range	-55°C -150°C
Total error in the whole temperature zone <sup>7</sup>	A、 B Zero drift < $\pm 1.5\% FS^5/100^\circ C$
	Full scale drift < $1.5\%FS^5/100^\circ C$
	D Total error <sup>6</sup> < $0.5\% FS^5/100^\circ C$

### Electrical Interface Definition

Electrical connector	Pin Definition	Electrical Output		
		A	B	D
8	Red	Vin+	Vin+	Vin+
	Green	Vout+	Vout+	Vout+
	White	Vout-	Vout-	
	Black	Vin-	Vin-	Vin-

- 1: Custom compound ranges can be specially ordered, for example, (5-100)KPaA.
- 2: Pressure overload below this limit does not affect product performance.
- 3: This is the safe upper limit for the sensor; exceeding this value may cause leakage or deformation.
- 4: Temperature performance refers to the performance within the compensated temperature range.
- 5: FS = Full Scale (Full Range).
- 6: Error based on the best endpoint line fit.
- 7: Refer to China's national standard GB/T 15478-2015

**Outline Drawing**

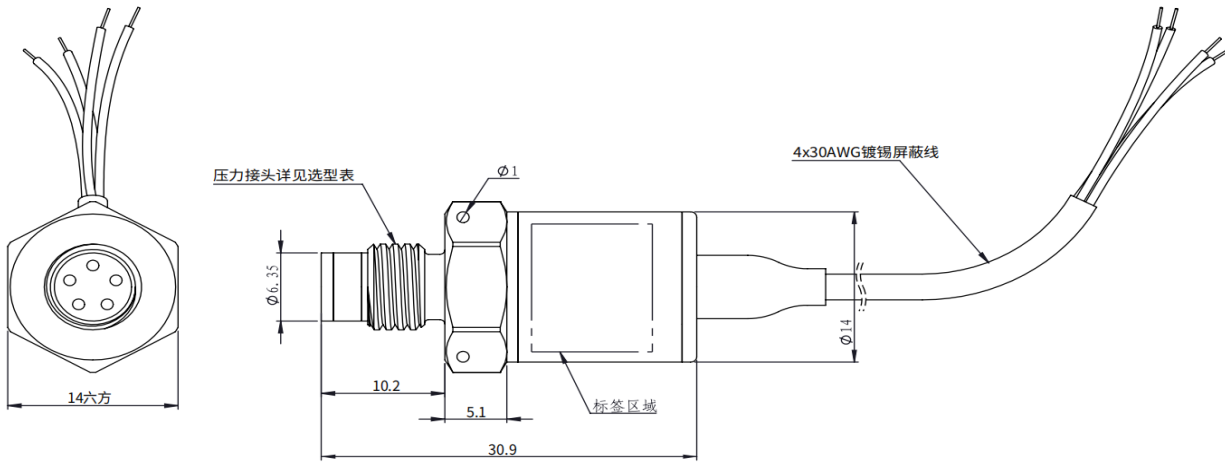

**Pressure fittings & Recommended installation drawings**

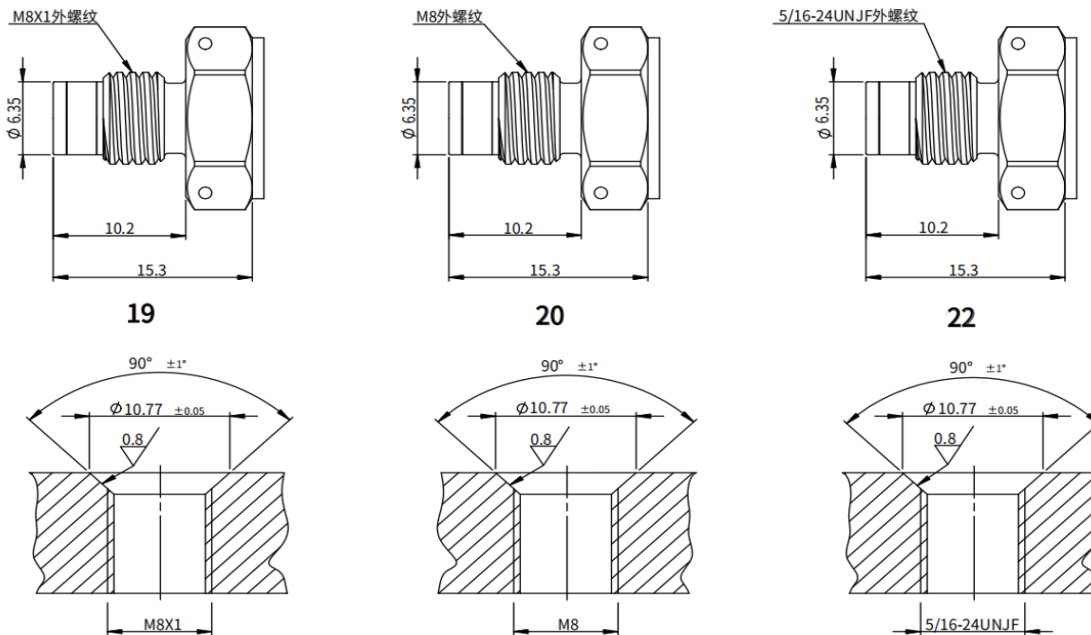

Installation torque: Measuring range 0~35 MPaA, 10N.m  
Measuring range 35~70 MPaA, 22N.m

O-ring: inner diameter 7.65mm, wire diameter 1.63mm,  
material and measured medium match

# DATASHEET

## PRESSURE MEASUREMENT

Dabey Technology Co., LTD  
 Sales@dabeysensor.com  
 86-18890003683  
 www.dabeysensor.com

How to Order? Look at the selection table below

### Model NO

#### MPT800

#### Signal output

- A 0~100mV output, 10VDC powered, output proportional to supply voltage, four-wire.
- B 0~100mV output, 8-16VDC powered, output independent of supply voltage, four-wire.
- D 0.5~4.5V output, 8~32VDC powered, high-precision digital compensation, three-wire

#### Circuit Connections

8 4x30AWG (1m length) tinned shielded wire

Note:Other specifications are available upon request.

#### Pressure Connection Fittings

- 19 M8X1 external thread
- 20 M8 external thread
- 22 5/16-24UNJF external thread

Note:Other specifications are available upon request

#### Compensation Temperature Range

TA	25°C~80°C	TE	-10°C~50°C
TB	-20°C~125°C	TF	-20°C~80°C
TC	-40°C~125°C	TG	-40°C~80°C

#### Accuracy

- A1 0.2%FS BFSL
- A2 0.1%FS BFSL

#### Calibration Report

- CA Ambient temperature six-point pressure data
- CB Five-point full-temperature data

#### Pressure Range

- 0~70
- 0~70

#### Unit

- MPa
- MPa

#### Type

- A (Absolute Pressure)
- S (Sealed Gauge Pressure)

#### Special Requirements

Refer to the purchase contract for details on 'S'.

MPT800 A 8 19 TA A1 CA 0-20 MPA A S

MPT800-A819TAA1CA, 0~20Mpa, A